

Hearing Loop for Door Entry Systems

DCIL-EL42-PB / DCIL-EL42-PF



Installation Guide

April 2019

Contents

Product Overview	3
Components	3
Connections	4
Installation Instructions - Standard	6
Installation Instructions - Flush	8

Contacta has a policy of continuous product development, therefore small specification changes may not be reflected in this manual. Images, labels, packaging, accessories and product colours are subject to change without notice.

Product Overview

This hearing loop is for use with door entry systems, providing clear audio to hearing device wearers. Both standard and flush versions of the unit are available.

Components

IL-EL42-PB - Standard

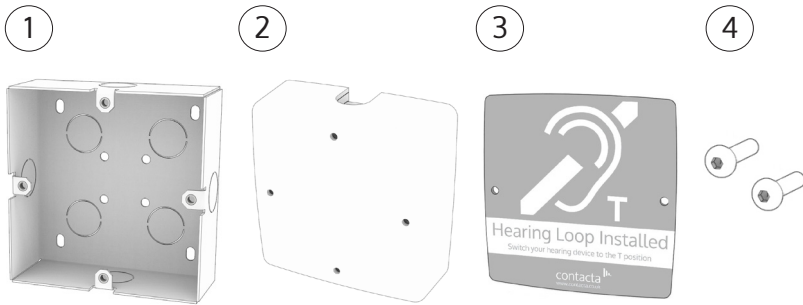

1. Back box
2. Front cover [containing PCB for Connections (see page 4)]
3. Front sticker
4. M4 x 16mm socket bolt screw

IL-EL42-PF - Flush

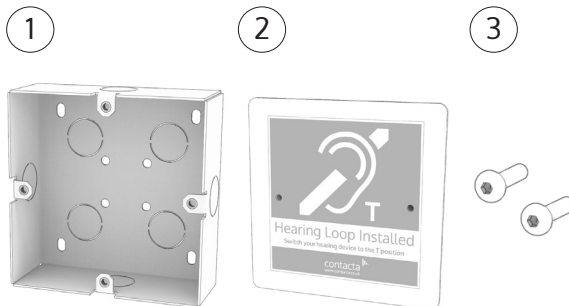

1. Back box
2. Face plate [containing PCB for Connections (see page 4)]
3. M4 x 16mm socket bolt screw

Connections

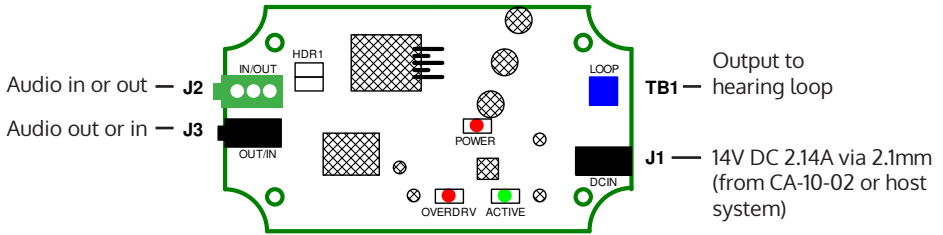

Power Supply

- We recommend the unit is powered using a CA-10-02 Power Supply through port J1. If using a host system, ensure it meets the following specifications:
 - Supply voltage: 14V DC
 - Current output: 2A minimum
 - 2.1mm power connector jack
- J1 is a 2.1mm DC jack with centre pin positive.

Audio Input Connection

- J2 is an audio input connection [100V line].
- J2 and J3 are connected in parallel and are therefore interchangeable. They are ohmically ground isolated and have series resistance to prevent interaction due to the paralleling of stereo channels within the system.

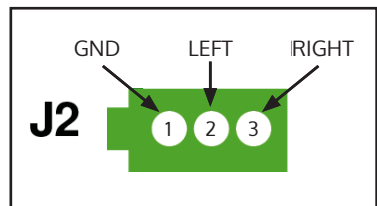
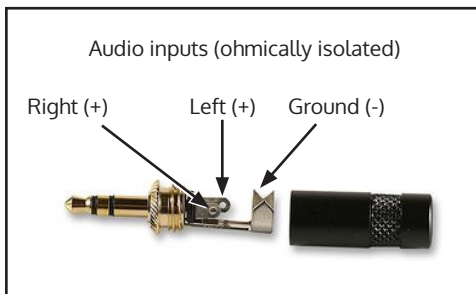

Audio Input Signal

- Standard recommended input:
Computer sound card signal with typical 1 volt RMS.
- Typical levels for larger speakers can be accepted by removing the two jumpers on header HDR1.
- 100V 'Line' can be accepted in J2.

LEDs

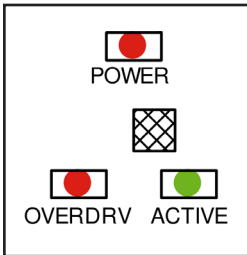

POWER - Constantly lit red to indicate the device is powered on.

ACTIVE - Illuminates green when a loop is being driven correctly.

OVERDRIVE - Becomes increasingly steady red as an audio signal increases. If it is continuously red, the drive level of the loop is too high and audio may be distorted.

If the ACTIVE LED is not illuminated and the OVERDRIVE LED is constantly illuminated, the induction loop is disconnected or open-circuit. Remedial action must be taken.

Installation Instructions - Standard

1. Identify and mark the mounting surface for the hearing loop's back box installation. Ensure any cables can be fed to the chosen location and into the unit.
2. On the sides of the back box, there are 8 circular blanks (see below). Select an appropriate blank and remove it to create a hole through which connections can enter the unit.

Note: If using a conduit, ensure the punched out hole is in an appropriate location. The conduit should have an outer diameter no more than 22.5mm and be fitted with a watertight seal.

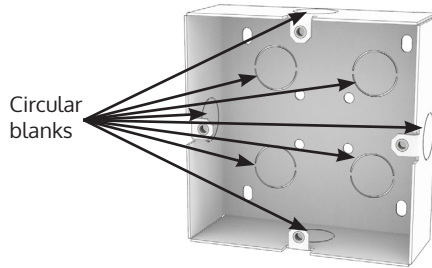

3. Using the outer 4 fixing points (see below), screw the back box into place. Use 4 fixing screws (not supplied) suitable for the installation location's construction material. If using a conduit, fit it to the back box and feed through cabling.

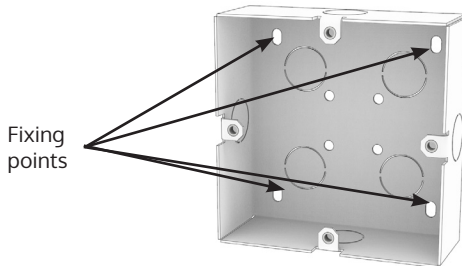

4. Connect the unit's PCB – located inside the front cover – to both a power source and the relevant door entry system (see Connections on page 4).

5. Place the front cover onto the back box. If using a conduit, align it with the unit's cutout. If not using a conduit, position the cutout at the bottom of the unit.
6. Carefully apply the front sticker to the front cover, ensuring the horizontal holes are aligned.

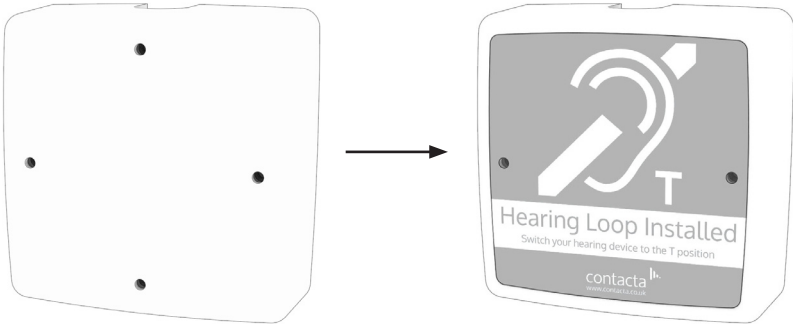

7. Screw the front cover to the back box using the provided socket bolt screws.

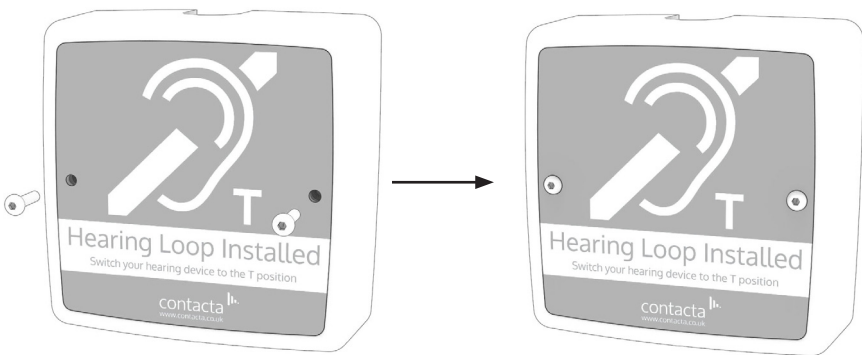

8. Use a sealant to create a weather-tight bond between the front cover and the mounting surface.
9. Installation is now complete. The Hearing Loop for Door Entry systems is plug-and-play, meaning no further setup is required.

Installation Instructions - Flush

1. Identify and mark the surface for the hearing loop's back box installation. Ensure any cables can be fed to the chosen location and into the unit.
2. Create a 115mm x 115mm hole with 43mm depth in the required installation location. This will contain the unit's back box.
3. On the sides of the back box, there are 8 circular blanks (see below). Select an appropriate blank and remove it to create a hole through which connections can enter the unit.

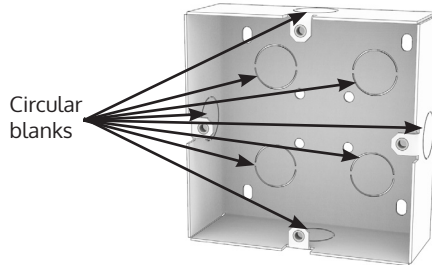

4. Using the outer 4 fixing points (see below), screw the back box into place. Use 4 fixing screws (not supplied) suitable for the installation location's construction material. If using a conduit, fit it to the back box and feed through cabling.

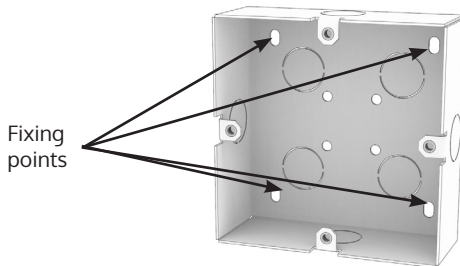

5. Connect the unit's PCB – located on the rear of the face plate – to both a power source and the relevant door entry system (see Connections on page 4).

6. Place the face plate onto the back box.
7. Screw the face plate to the back box using the provided socket bolt screws (see below).

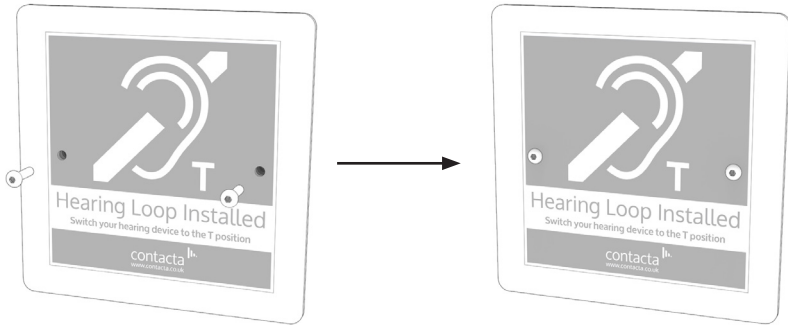

8. Use a sealant to create a weather-tight bond between the front cover and the mounting surface.
9. Installation is now complete. The Flush Hearing Loop for Door Entry Systems is plug-and-play, meaning no further setup is required.

Troubleshooting

Symptom	Possible Fault	Action Required
POWER LED not illuminated	Power supply disconnected or failed	Investigate power supply
POWER LED illuminated Other LEDs not illuminated	No audio input	Investigate audio feed
POWER LED illuminated ACTIVE LED flickering or steady OVERDRIVE LED off or occasionally flickering	Correct operation, although audio input is potentially low	Increase audio level (if possible)
POWER LED illuminated ACTIVE LED flickering or steady OVERDRIVE LED flickering regularly	Good operation	No action
POWER LED illuminated ACTIVE LED off OVERDRIVE LED illuminated	Induction loop disconnected, open circuit, or incorrect specification	Investigate loop and its connections
Interference (buzzing / whistling / hissing) is heard through hearing loop	Unscreened or poorly earthed third party equipment is being used in HOST or in close proximity Incorrect power supply	Switch off any third party equipment to identify the source of interference CA-10-02 Power Supply is recommended to aid in screening interference



Local dealer

Audio

ACCESSIBILITÉ

Audio Accessibilité By ARCHEAN Technologies

✉ 1899 Avenue d'Italie, ZI Alba sud II, 82000 Montauban, France

☎ +33 (0)5 63 93 50 00

✉ contact@audioaccessibilite.tech

www.audioaccessibilite.tech